

LORAM®

YARDGLIDE® WL1000



The Total Yard Solution

Speed, Performance, Reliability

YARDGLIDE® WL 1000

is an intelligent lubrication system that applies a clean friction modifier on the wheels of a rolling railroad car in a yard.

How it Works.

YardGlide® WL1000 is not a greaser. It uses a Friction Modifier (FM) to achieve powerful results with no mess. The FM is water-based and biodegradable. This means a cleaner and less hazardous track environment. **YardGlide®** WL1000 is usually installed after each group retarder in a hump yard or after the master retarder in a flat yard. It does not fire on locomotive wheels and cars traveling towards the hump.

The system is composed of three wheel sensors, a pair of proprietary nozzle/valve systems, and a controller enclosure with a friction modifier reservoir. The fluid is applied to the wheels via a pair of jets which hit both lead wheels of a car truck as it exits a retarder.

Benefits.

- Minimized car speed loss
- Reduced stalls and trim
- Reduced car / track maintenance
- Reduced lateral forces and noise on sharp curves

- Fewer load shift adjusts
- Fewer collisions
- Reduced conditions that can cause derailments
- Fewer rollouts
- No tipped rail
- Cleaner yard conditions
- Improved yard productivity

Enhanced Performance and Accuracy.

The friction modifier dispensed by **YardGlide®** WL1000 is a clear, environmentally clean, synthetic organic liquid called TOR-CL (top-of-rail curve friction modifier). It is not petroleum based. It is a non-toxic, water-based polymer solution. When applied in very small quantities to the flange and tread of a car wheel, car rolling is improved.

Reliable Service and Support.

With more than 30 years of helping railroads extend rail life through rail grinding, Loram has now added the most advanced friction modification systems in the industry to our product offerings. Extend the life of your rail assets, select Loram's Maintenance of Way Products.

For more information visit www.loram.com or call your local Loram Regional Manager.

Specifications

YARDGLIDE® WL1000

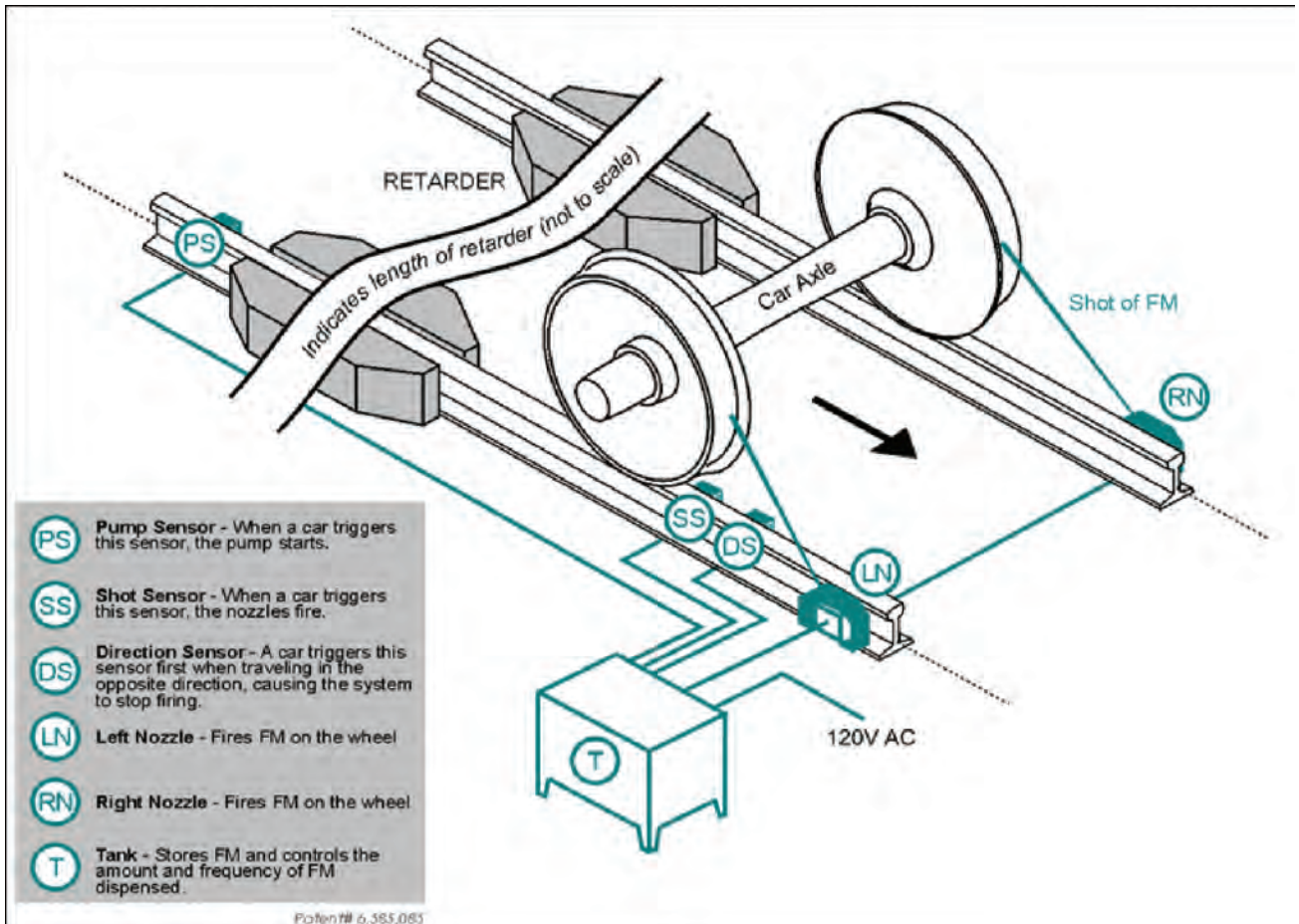

YardGlide® WL1000



Wheel Detection System



YardGlide® WL1000 in action

YardGlide® WL1000 Makes a Difference!

	Grease System	YardGlide™ WL1000
Car Rolling Effectiveness	Poor	Excellent
Cleanliness	Poor	Excellent
Operating Cost per Day	High	Low
Maintenance	High	Low
Probability of Tipped Rail	High	Low

Subject to change

LORAM

Speed, Performance, and Reliability

Loram Maintenance of Way, Inc.

3900 Arrowhead Drive
 Hamel, Minnesota 55340 USA
 Tel. (763) 478-6014 (800) 328-1466
 Fax (763) 478-2221
 www.loram.com
 sales@loram.com